

PLAN
SCALE 3/32" = 1'-0"

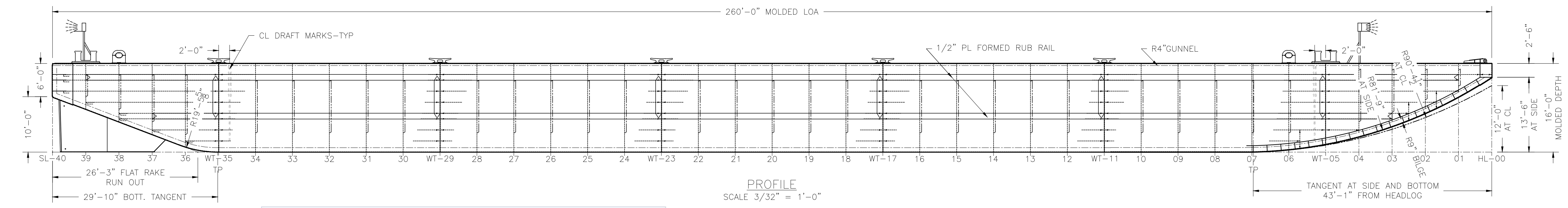

PROFILE
SCALE 3/32" = 1'-0"

CBC 1271-1272--260'-0" x 72'-0" x 16'-0" Ocean Deck
Barge Deadweight Table

MLD. DRAFT. FEET	SALT WATER DISPLACEMENT L. TONS	FRESH WATER DISPLACEMENT L. TONS	DEADWEIGHT L. TONS S.W.	DEADWEIGHT L. TONS F.W.	DEADWEIGHT S. TONS S.W.	DEADWEIGHT S. TONS F.W.
3.000	1,284.00	1,252.88	214.53	766.80	240.27	858.60
3.500	1,512.00	1,475.12	442.53	989.04	495.63	1,107.73
4.000	1,743.00	1,700.49	673.53	1,214.41	754.35	1,360.14
4.500	1,975.90	1,927.71	906.43	1,441.63	1,015.20	1,614.62
5.000	2,212.30	2,158.34	1,142.83	1,672.26	1,279.97	1,872.93
5.500	2,451.30	2,391.51	1,381.83	1,905.43	1,547.65	2,134.08
6.000	2,693.00	2,627.32	1,623.53	2,141.24	1,818.35	2,398.19
6.500	2,936.20	2,864.59	1,866.73	2,378.51	2,090.74	2,663.93
7.000	3,181.00	3,103.41	2,111.53	2,617.33	2,364.91	2,931.41
7.500	3,430.50	3,346.83	2,361.03	2,860.75	2,644.35	3,204.04
8.000	3,682.00	3,592.20	2,612.53	3,106.12	2,926.03	3,478.85
8.500	3,935.70	3,839.71	2,866.23	3,353.63	3,210.18	3,756.06
9.000	4,191.30	4,089.07	3,121.83	3,602.99	3,496.45	4,035.35
9.500	4,448.40	4,339.90	3,378.93	3,853.82	3,784.40	4,316.28
10.000	4,708.50	4,593.66	3,639.03	4,107.58	4,075.71	4,600.49
10.500	4,970.10	4,848.88	3,900.63	4,362.80	4,368.71	4,886.33
11.000	5,232.50	5,104.88	4,163.03	4,618.80	4,662.59	5,173.05
11.500	5,495.70	5,361.66	4,426.23	4,875.58	4,957.38	5,460.65
12.000	5,759.80	5,619.12	4,690.13	5,133.04	5,252.95	5,749.01
12.500	6,022.40	5,875.51	4,952.93	5,389.43	5,547.28	6,036.16
13.000	6,286.10	6,132.78	5,216.63	5,646.70	5,842.63	6,324.30
13.500	6,550.80	6,390.83	5,481.13	5,904.75	6,138.87	6,613.32
14.000	6,815.10	6,648.88	5,745.63	6,162.80	6,435.11	6,902.33
14.500	7,079.50	6,906.63	6,010.03	6,420.75	6,731.23	7,191.24
15.000	7,344.00	7,164.88	6,274.53	6,678.80	7,027.47	7,480.25
15.500	7,608.40	7,422.83	6,538.93	6,936.75	7,323.60	7,769.16
16.000	7,872.50	7,680.49	6,803.03	7,194.41	7,619.39	8,057.74

M. Dan Jones & Associates
NAVAL ARCHITECTS MARINE CONSULTANTS
SUGAR LAND, TX
(281) 343-1686

CANAL BARGE CO. INC.
HULL NO'S 6019 & 6020
260'x72'x16' 4500 #/SQFT DECK BARGE

DR. SRS CK. MDJ
DATE 01/11 APP'D. CBC
TITLE GENERAL ARRANGEMENT

This design and drawing are the exclusive properties of M. Dan Jones & Assoc. and are furnished strictly on a confidential basis. No portion of this drawing may be copied, traced, photographed, or in any other way reproduced nor may any item hereon depicted be manufactured as shown without the written consent of M. Dan Jones & Assoc. The recipient of the information contained hereon may not disclose the same to any other person, nor may he use such information except for the specific purpose intended.

SCALE AS NOTED DWG. NO. 0-01 ALT. 1